

# Technical Specifications – WPOZ 3000

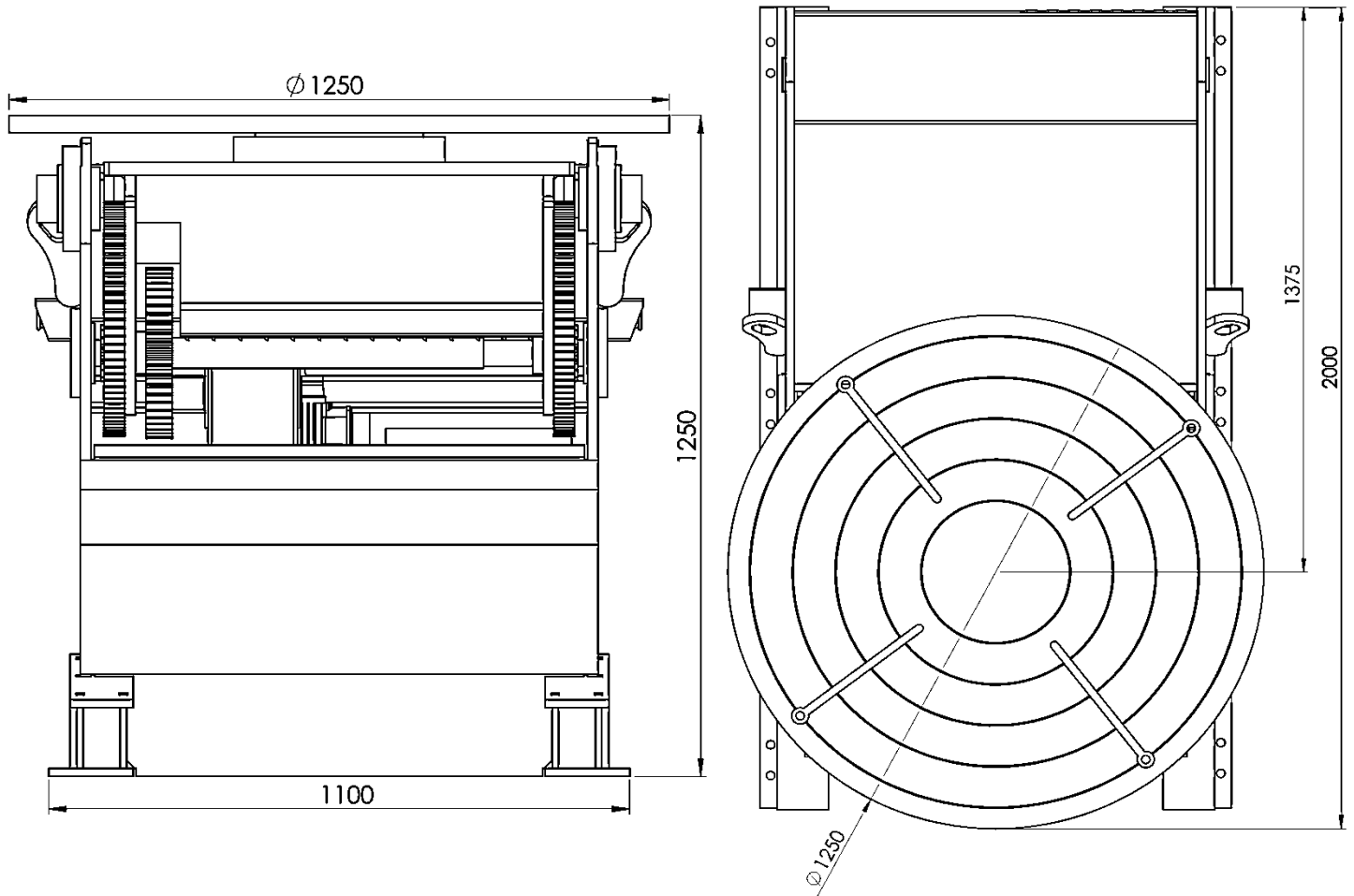

Max. Load (N)	30000
Axis Eccentricity	150mm for Rotation and Tilting
Rotation Speed (rpm/min)	Min 0,1 – Max 1 at 5 Hz – 50 Hz Range
Rotation Torque (kg.m)	450
Rotation Motor	1 x 1,5 Kw AC Motor
Tilting Angle	120°
Tilting Speed from 0 to 120	90 second
Tilting Torque (kg.m)	960
Tilting Motor	1 x 0,75 Kw AC Motor
Driver	1.5 Kw
Face Plate Diameter	1250 mm
Fixing Slots	4 T-Slots / M16 (it can be M18 or anyelse)
Control Device	Standing Control Panel
Incoming Supply	380V/400V, 3Ph, 50Hz @ 5 – 50 Hz
Applicable Optional	Hand Pendant & Foot Pedal
Colour	RAL6025 - GREEN/Texture Painting
Welding Torch Holder	No
Shipping Dimension & Weight	Width 1480mm x Length 2230mm x Height 1570mm / 1850 Kg